

BULETINUL INSTITUTULUI POLITEHNIC DIN IAȘI  
Publicat de  
Universitatea Tehnică „Gheorghe Asachi” din Iași  
Tomul LXI (LXV), Fasc. 1, 2015  
Secția  
CONSTRUCȚII DE MAȘINI

**INFLUENCE OF SOME EXTERNAL FACTORS  
ON MAGNETO-RHEOLOGICAL FLUID (MRF) FLOW  
THROUGH CIRCULAR PIPES**

BY

**DORU CĂLĂRAȘU, DAN SCURTU and BOGDAN CIOBANU\***

“Gheorghe Asachi” Technical University of Iași, România,  
Department of Fluid Mechanics, Fluid Machinery and Fluid Power Systems

Received: January 21, 2015

Accepted for publication: February 14, 2015

**Abstract.** Today, a growing number of applications from industry, and not only from that domain develop based on smart materials. These materials are able to change shape, size and properties to changes in temperature, humidity or by applying an external magnetic field. The applications of magneto-rheological fluids are found in different areas with major environmental impact such as automotive, civil and special buildings, medical devices industry, military industry etc. The use of magneto-rheological fluids in various applications requires a good knowledge of their behaviour in terms of complex flow properties. The paper proposes a mathematical model of the flow of a magneto-rheological fluid, with pressure gradient, through a circular pipe using the Navier-Stokes equation in cylindrical coordinates and the experimental analysis of this phenomenon.

**Key words:** magneto-rheological fluid (MRF); circular pipe; Navier-Stokes; Bingham fluid.

---

\*Corresponding author; *e-mail*: bogdancioban@yahoo.com

## 1. Introduction

Recent research focuses on developing new materials that can respond properly to various applications imposed by environmental changes and adapt their properties to a wide range of external factors.

Today, a growing number of applications from industry, and not only from that domain, develop based on smart materials. These materials are able to change shape, size and properties to changes in temperature, humidity or by applying an external magnetic field.

Most materials have physical properties that cannot be significantly modified. However, smart materials have certain properties which can be changed relatively easily such as viscosity, volume and conductivity. These properties that can be relatively easily modified are the ones that determine to what type of applications can be used the smart material (Kciuk & Turczyn, 2006).

The applications of magneto-rheological fluids (Zhou *et al.*, 1998) are found in different areas with major environmental impact such as automotive (Huang *et al.*, 2002; Chen *et al.*, 2012), civil and special buildings (protection against the effects of earthquakes (Carlson & Spencer, 1996), shock (Pranoto & Nagaya, 2005) and vibration (Muhammad *et al.*, 2006) absorption), medical devices industry (prostheses (Klingenberg, 2001) and muscle rehabilitation equipment (Avraam, 2009)), military industry (Craig, 2003) etc.

Using of magneto-rheological fluids (Klein *et al.*, 2005) allows:

- real-time control of the position, movement (to lock) and dumping;
- high dissipative force independent of velocity;
- greater energy density;
- simple design;
- quick response time (milliseconds);
- minimal power usage.

The use of magneto-rheological fluids in various applications requires a good knowledge of their behaviour in terms of complex flow properties (Siginer *et al.*, 1999).

The paper proposes a mathematical model of the flow of a magneto-rheological fluid, with pressure gradient, through a circular pipe using the Navier-Stokes equation in cylindrical coordinates and the experimental analysis of this phenomenon.

## 2. Magneto-Rheological Fluid Flow Models

Magneto-rheological fluids are mostly non-Newtonian, Bingham type, fluids.

For Bingham type fluids, the kinematic and energetic flow characteristics differ from those of Newtonian fluid. The law of variation of the total yield stress  $\tau$  is given by eq. (1):

$$\tau = \tau_0 + \eta \frac{dv}{dn} \quad (1)$$

where:  $\tau_0$  is the basic yield stress and  $\eta \frac{dv}{dn}$  is the shear stress.

Magneto-rheological fluids are characterized by the fact that their energizing is done through an external magnetic field that affect the both components of the total yield stress. These fluids can be classified as smart fluids. If a magnetic field is applied to such a fluid, the result is the modification of the basic yield stress.

Specific to flow of Bingham type fluids is the formation of a fluid stopper in the central area of flow where the speed is constant. The diameter of the fluid stopper depends on characteristics of the fluid, the flow field geometry and the external stimuli.

Between the border of fluid stopper and the wall of the physical system, the flow is described by real fluid equations.

Taking into account the relatively large size of the magnetic particles from the magneto-rheological fluid, in terms of applying an external magnetic field, the concentration of magnetic particles varies continuously in the flow area. Thus, the viscosity varies in the flow area.

Considering the complexity of systems with magnetic controllable fluids, a full analysis of these systems is difficult. Mathematical models of dynamics of real fluids in combination with mathematical models specific to ferromagnetism phenomenon can be used for the study of flow of mentioned fluids.

The literature provides several models for magneto-rheological fluid flow.

The Herschel-Bulkley model (Herschel & Bulkley, 1926) allows the calculation of stress  $\tau$  for values of magnetic induction  $B > 0$ . The Buckingham-Reiner model (Bird *et al.*, 1960) gives a relation for calculating the flow rate of magneto-rheological fluid flow in a circular pipe. The Chilton and Stainsby model (Chilton & Stainsby, 1998) propose an equation for calculating the pressure drop for a magneto-rheological fluid flow in laminar conditions. Goncalves (2005) presents the parallel flow model of a magneto-rheological fluid placed between two fixed parallel plates on which acts a magnetic field. The model allows determining the kinematic characteristics of flow. David *et al.* (2011) propose a theoretical model for magneto-rheological fluid flow through annular spaces, characterized by the relative motion of solid boundaries. Janusz and Sapinski (2012) present the results of some theoretical and experimental studies on the operation of magneto-rheological fluid dampers.

Experimental results and technical achievements, using magneto-rheological fluids, were obtained at the Laboratory of Magnetic Fluids from Center for Fundamental and Advanced Technical Research of Romanian Academy - Timișoara Branch (Susan-Resiga, 2007). At National Center for

Complex Fluids Engineering Systems from “Politehnica” University from Timișoara (2010) have been experimentally determined the rheological characteristics for magneto-rheological fluid MRF-140 LP used in technical applications (Susan-Resiga *et al.*, 2010).

The LORD Company from USA (www.lord.com) presents results of their own experimental research. The main applications developed by the company, using magnetic controllable fluids, are in several areas such clutches, dampers, prostheses for human joints, electrically controlled braking devices etc.

Current researches are considering expanding the areas of use of magneto-rheological fluids.

The paper proposes a mathematical model for the magneto-rheological fluid flow with pressure gradient in a circular pipe, using the Navier-Stokes equation in cylindrical coordinates. The model allows determining the flow characteristics through a circular pipe with known geometry for the fluid MRHCCS4-B produced by Liquids Research Limited (www.liquidresearch.com). Experimentally results are presented and compared with results obtained with the proposed mathematical model.

### 3. The Laminar Theoretical Model of a Magneto-Rheological Fluid in a Circular Pipe Under the Action of a Pressure Gradient

To describe the laminar flow of Bingham type fluids, the Navier-Stokes equations are used.

The paper aims to determine the parameters characterizing the flow of a magneto-rheological fluid in a horizontal pipe with circular cross-section, in the absence of an external magnetic field.

Considering the flow to be axially-symmetric, Navier-Stokes equations in cylindrical coordinates  $(r, \varphi, z)$  (eq. (2)) is used:

$$\begin{cases} \frac{\partial v_r}{\partial t} + v_r \frac{\partial v_r}{\partial r} + \frac{v_\varphi}{r} \frac{\partial v_r}{\partial \varphi} + v_z \frac{\partial v_r}{\partial z} - \frac{v^2 \varphi}{r} = f_r - \frac{1}{\varphi} \frac{\partial p}{\partial r} + \mathcal{G} \left( \Delta v_r - \frac{v_r}{r^2} - \frac{2}{r^2} \frac{\partial v_\varphi}{\partial \varphi} \right), \\ \frac{\partial v_\varphi}{\partial t} + v_r \frac{\partial v_\varphi}{\partial r} + \frac{v_\varphi}{r} \frac{\partial v_\varphi}{\partial \varphi} + v_z \frac{\partial v_\varphi}{\partial z} + \frac{v_r v_\varphi}{r} = f_\varphi - \frac{1}{\varphi r} \frac{\partial p}{\partial \varphi} + \mathcal{G} \left( \Delta v_\varphi + \frac{2}{r^2} \frac{\partial v_r}{\partial \varphi} - \frac{v_\varphi}{r^2} \right), \\ \frac{\partial v_z}{\partial t} + v_r \frac{\partial v_z}{\partial r} + \frac{v_\varphi}{r} \frac{\partial v_z}{\partial \varphi} + v_z \frac{\partial v_z}{\partial z} = f_z - \frac{1}{\varphi} \frac{\partial p}{\partial z} + \mathcal{G} \Delta v_z \end{cases} \quad (2)$$

where  $\vec{V}(r, \varphi, z)$  is the velocity of permanent moving of the real fluid with kinematic viscosity  $\mathcal{G}$ , given by eq. (3):

$$\vec{V}(r, \varphi, z) = v_r(r, \varphi, z) \vec{e}_r + v_\varphi(r, \varphi, z) \vec{e}_\varphi + v_z(r, \varphi, z) \vec{k} \quad (3)$$

It was noted  $\Delta = \frac{\partial^2}{\partial r^2} + \frac{1}{r} \frac{\partial}{\partial r} + \frac{1}{r^2} \frac{\partial^2}{\partial \varphi^2} + \frac{\partial^2}{\partial z^2}$ .

The equation of continuity (eq. (4)), in cylindrical coordinates, is:

$$\frac{1}{r} \frac{\partial}{\partial r} (r \cdot v_r) + \frac{1}{r} \frac{\partial v_\varphi}{\partial \varphi} + \frac{\partial v_z}{\partial z} = 0 \quad (4)$$

Navier-Stokes equations (eq. (2)) together with the equation of continuity (eq. (4)) allow the solving of real fluid motion if boundary conditions are known.

The unidirectional flow of a fluid, with speed  $\vec{V}$ , through a circular pipe with radius  $R$ , under the action of a pressure gradient, (Fig. 1), it is considered. In these conditions,  $v_r = 0$ ;  $v_\varphi = 0$ ;  $v_z \neq 0$ .

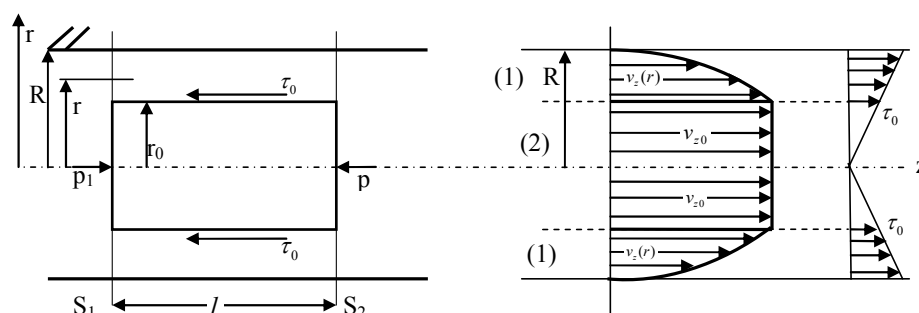

Fig. 1 – The model of flow with pressure gradient for magneto-rheological fluid through a circular pipe.

If we neglect the mass forces  $f_r = f_\varphi = f_z = 0$  and using the equation of continuity in given conditions, we obtain the dynamic equilibrium equation (eq. (5)):

$$\eta \frac{d^2 v_z}{dr^2} + \frac{1}{r} \frac{dv_z}{dr} = \frac{dp}{dz} \quad (5)$$

Considering the expression of yield stress for non-Newtonian Bingham type fluids  $\tau = \tau_0 + \eta \frac{dv_z}{dr}$ , eq. (6) is obtained:

$$\frac{\partial \tau}{\partial r} + \frac{\tau}{\eta r} = \frac{\partial p}{\partial z} \quad (6)$$

Flow field can be separated into two distinct sub-domains (Fig. 1). In the sub-field (1) for  $r \in [r_0; R]$ , the shear stress is high and the speed has a continuous variation along the radius. In the sub-field (2) for  $r \in [0; r_0]$ , the fluid is moving with constant speed in the form of a firm fluid stopper. In this region the basic yield stress was not exceeded and the fluid is not tore.

The expressions of the velocities of flow in the two sub-domains can be obtained by applying the boundary conditions for flow velocity  $v_z$ .

The solution to eq. (1) is given by eq. (7):

$$v_z(r) = \frac{\Delta p}{4 \cdot \eta \cdot l} r^2 + \frac{\tau_0}{\eta} r + c_1 \ln r + c_2 \quad (7)$$

Integration constants  $c_1$  and  $c_2$  are determined from the boundary conditions:

• for  $r = r_0$  (border of fluid stopper),  $\frac{dv_z}{dr} = 0$  and eqs. (8-11) can be written:

$$\frac{dv_z}{dr} = \frac{2 \cdot r \cdot \Delta p}{4 \cdot \eta \cdot l} + \frac{\tau_0}{\eta} + c_1 \frac{1}{r} \quad (8)$$

$$\frac{r_0^2 \cdot \Delta p}{2 \cdot \eta \cdot l} + \frac{\tau_0 \cdot r_0}{\eta} + c_1 = 0 \quad (9)$$

$$c_1 = -\frac{\Delta p}{2 \cdot \eta \cdot l} r_0^2 - \frac{\tau_0}{\eta} r_0 \quad (10)$$

$$v_z(r) = \frac{\Delta p}{4 \cdot \eta \cdot l} r^2 + \frac{\tau_0}{\eta} r - \frac{\Delta p}{2 \cdot \eta \cdot l} r_0^2 \ln r - \frac{\tau_0}{\eta} r_0 \ln r + c_2 \quad (11)$$

• for  $r = R$  (at the wall),  $v_z(R) = 0$  and eqs. (12-13) can be written:

$$\frac{\Delta p}{2 \cdot \eta \cdot l} \left[ \frac{R^2}{2} - r_0^2 \ln R \right] + \frac{\tau_0}{\eta} [R - r_0 \ln R] + c_2 = 0 \quad (12)$$

$$c_2 = -\frac{\Delta p}{2 \cdot \eta \cdot l} \left[ \frac{R^2}{2} - r_0^2 \ln R \right] - \frac{\tau_0}{\eta} [R - r_0 \ln R] \quad (13)$$

The expression of velocity  $v_z(r)$  in sub-domain (1), for  $r \in [r_0; R]$ , is given by eq. (14):

$$v_z(r) = \frac{\Delta p}{2 \cdot \eta \cdot l} \left[ \frac{R^2}{2} - \frac{r^2}{2} + r_0^2 \ln \frac{R}{r} \right] + \frac{\tau_0}{\eta} \left[ R - r + r_0 \ln \frac{R}{r} \right] \quad (14)$$

From the equation of equilibrium of pressure and friction forces on the fluid control volume corresponding to the fluid stopper with radius  $r_0$  and length  $l$  (eq. (15)), we obtain the radius of fluid stopper (eq. (16)):

$$(p_1 - p_2) \pi r_0^2 = 2 \tau_0 r_0 \pi l \quad (15)$$

$$r_0 = \frac{2 \tau_0 l}{\Delta p} \quad (16)$$

The velocity of the fluid stopper (eq. (17)) can be obtained by imposing the condition  $r = r_0$  in velocity expression (eq. (14)):

$$v_{0z} = \frac{\Delta p}{2 \cdot \eta \cdot l} \left[ \frac{R^2}{2} - \frac{r_0^2}{2} + r_0^2 \ln \frac{R}{r_0} \right] + \frac{\tau_0}{\eta} \left[ R - r_0 + r_0 \ln \frac{R}{r_0} \right] \quad (17)$$

#### 4. Numerical Results

The mathematical model described above allows the analytical calculation of the flow of magneto-rheological fluid in a circular pipe with known geometry under the influence of a pressure gradient.

The flow of magneto-rheological fluid MRHCCS4-B, manufactured by Liquids Research Limited, through a circular pipe with radius  $R = 1.25 \cdot 10^{-3}$  m and length  $l = 15 \cdot 10^{-2}$  m, is analyzed.

For the temperature of 30°C, in the absence of an externally applied magnetic field ( $H = 0$ ), the characteristics of magneto-rheological fluid are: dynamic viscosity  $\eta = 0.45$  Pa·s and basic yield stress  $\tau_0 = 12$  N/m<sup>2</sup>. Analytical calculation of fluid flow aims to determine the variation of the radius  $r_0$  of the fluid stopper, the fluid stopper velocity  $v_{z0}$  and flow velocity  $v_z$  for radius  $r$ . The average velocity of flow  $v_{zm}$  is determined related to the difference of pressure  $\Delta p$ . The numerical simulations were made for six values of the difference of pressure between the ends of the pipe, respectively:  $\Delta p_1 = 6.29 \cdot 10^3$  N/m<sup>2</sup>;

$\Delta p_2 = 1.495 \cdot 10^4 \text{ N/m}^2$ ;  $\Delta p_3 = 2.336 \cdot 10^4 \text{ N/m}^2$ ;  $\Delta p_4 = 3.19 \cdot 10^4 \text{ N/m}^2$ ;  
 $\Delta p_5 = 4.029 \cdot 10^4 \text{ N/m}^2$ ;  $\Delta p_6 = 4.873 \cdot 10^4 \text{ N/m}^2$ .

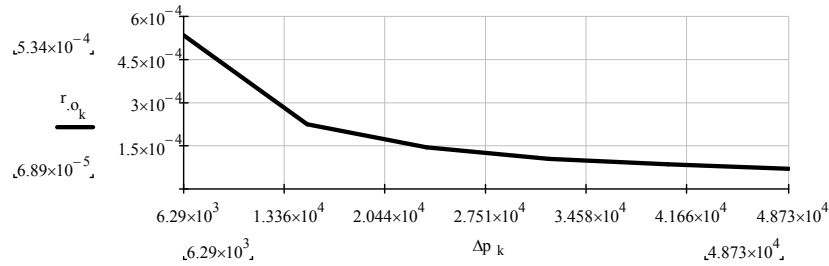

Fig. 2 – Influence of difference of pressure on fluid stopper radius.

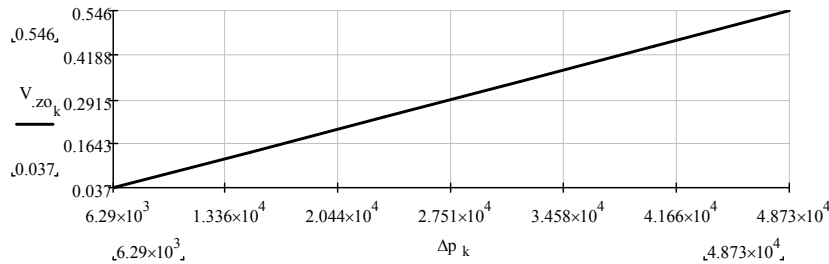

Fig. 3 – Influence of difference of pressure on velocity of fluid stopper.

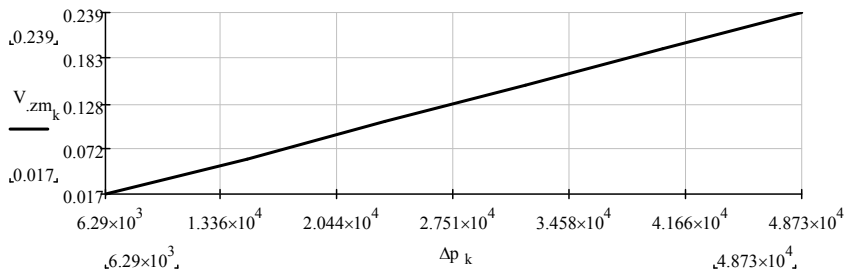

Fig. 4 – Influence of difference of pressure on mean velocity of fluid.

Analyzing the variation of fluid stopper radius  $r_0$  vs. difference of pressure  $\Delta p$  (Fig. 2) show that the increase of difference of pressure leads to decreases of radius of fluid stopper.

Downward gradient is greater in the area of small differences of pressure.

Analyzing the variation of local velocity of fluid between the fluid stopper border and the wall of hydraulic resistance  $v_{z0}$  vs. radius  $r$  at constant difference of pressure  $\Delta p = ct$ . (Fig. 5) show that the local velocity decreases with increasing of radius.



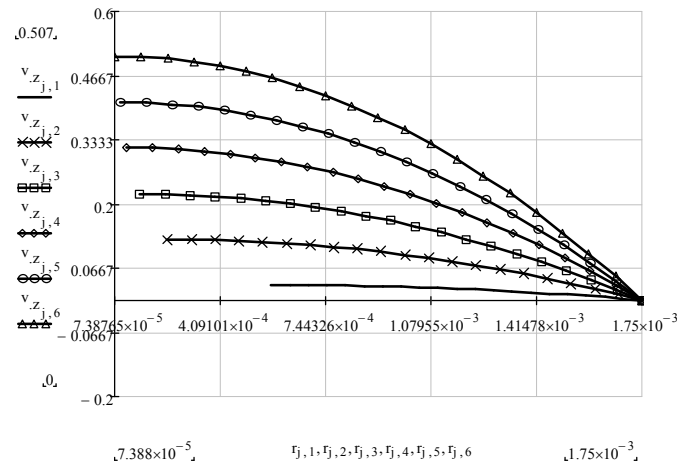

Fig. 5 – Variation of fluid velocity vs. pipe radius at constant difference of pressure.

At a certain radius  $r = ct.$ , in the pipe wall - fluid stopper border area, local velocity increases with increasing of difference of pressure.

Analyzing the variation of fluid stopper velocity vs. difference of pressure  $\Delta p$  (Fig. 3) show that the velocity increase linearly with the increase of difference of pressure.

Analyzing the variation of theoretical mean velocity of fluid through the hydraulic resistance vs. difference of pressure  $\Delta p$  (Fig. 4) show that the mean velocity increase linearly with the increase of difference of pressure.

### 5. Experimental Results

In order to validate the accuracy of the results obtained using the presented mathematical model, we have made experimental researches that relieve the behaviour of magneto-rheological fluid MRHCCS4-B in a cylindrical hydraulic resistance, at variable differences of pressure.

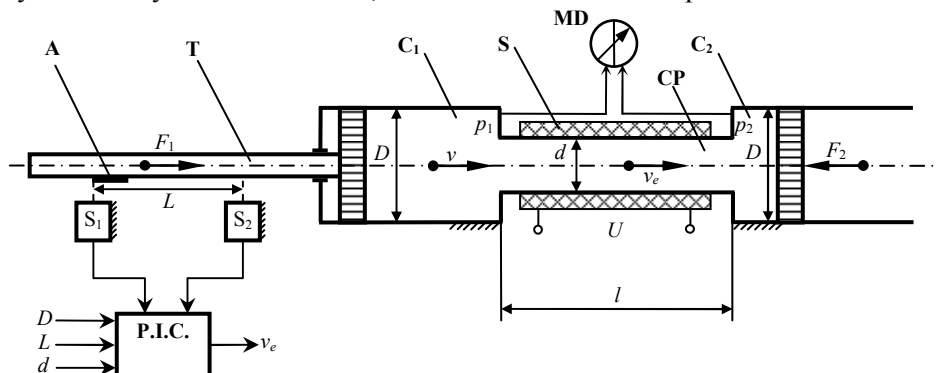

Fig. 6 – Sketch of the experimental stand.

Experimental tests have allowed the determining of mean velocity of the flow for fluid MRHCCS4-B.

Fig. 6 shows a simplified sketch of the experimental stand. The tests were made using, for the hydraulic resistance materialized by the circular pipe, the same parameters as in the theoretical model.

Experimental stand consists of two cylinders  $C_1$  and  $C_2$ , of diameter  $D$ . Between the two cylinders is sandwiched a pipe with diameter  $d$  and length  $l$ , through which flow the magneto-rheological fluid under the action of difference of pressure  $\Delta p$  given by forces  $F_1$  and  $F_2$ . The difference of pressure  $\Delta p = p_1 - p_2$  is read at differential manometer **MD**.

In order to determine the mean velocity of the fluid through the pipe, two inductive sensors of position,  $S_1$  and  $S_2$ , and a data processor are used. The GX458BML type sensors are placed at a distance  $L$  one from another. On the rod **T** of cylinder  $C_1$ , made from non-magnetic materials, is positioned the strip **A** which passes in front of the two sensors.

The signal from the two sensors is transmitted to PIC16F877A data processor which is programmed to determine:

- The time in which distance  $L$  is travelled;
- Mean velocity through the circular pipe by knowing the diameters  $D$  and  $d$ .

Experimental results are presented in Figs. 7 and 8.

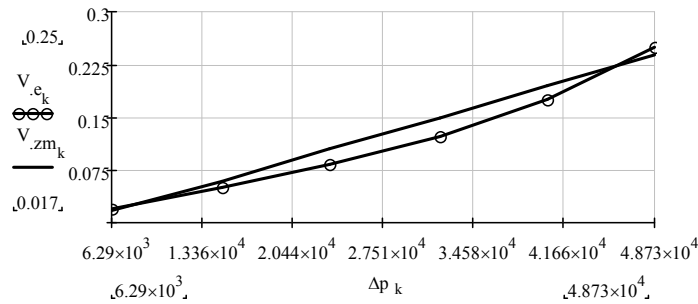

Fig. 7 – Theoretical and experimental mean velocity.

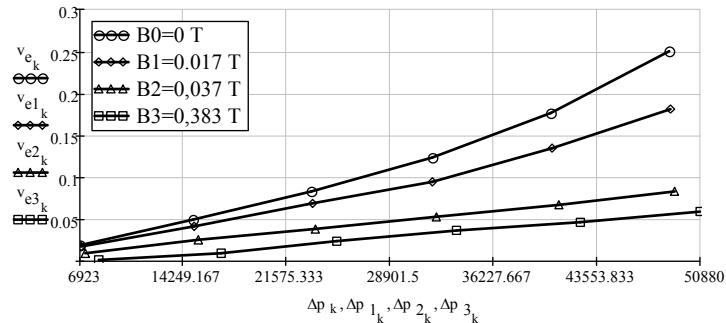

Fig. 8 – Influence of the induction  $B$  on the flow velocity.

Experimental tests were aimed to determine the influence of the difference of pressure  $\Delta p$  between the ends of hydraulic resistance on the velocity  $v_e$  of magneto-rheological fluid flow.

Characteristics presented in Fig. 7 show the variation of the theoretical mean velocity  $v_{zm}$  and experimental mean velocity  $v_e$  vs. the difference of pressure  $\Delta p$ , in the absence of the magnetic field. From the analysis of these characteristics results a good agreement between theoretical and experimental results.

Characteristics presented in Fig. 8 show the influence of the induction  $B$  of the external magnetic field on the flow velocity of magnetic fluid.

It is shown that, at constant difference of pressure, the mean velocity  $v_e$  decrease with the increasing of induction  $B$ . That means that the velocity of a magneto-rheological fluid through a circular pipe can be controlled with an external magnetic field, respectively by the variation of magnetic induction  $B$ .

## 6. Conclusions

1. The proposed mathematical model takes into consideration the axial-symmetric character of the flow. The model allows determining the behaviour of a magneto-rheological fluid that flow under a difference of pressure, through circular pipes.

2. The designed experimental stand allows the study of magneto-rheological fluid behaviour in the absence of the applied external magnetic field, as well as in its presence.

3. The experimental data obtained validate the proposed mathematical model.

4. Experimental tests carried out in the presence of applied external magnetic field show the possibility of controlling the flow parameters of a magneto-rheological fluid through circular pipes.

## REFERENCES

- Avraam T.M., *MR-Fluid Brake Design and its Application to a Portable Muscular Rehabilitation Device*. Ph. D. Thesis, Universite Libre de Bruxelles, Faculte des Sciences Appliquees, Department of Mechanical Engineering and Robotics, Bruxelles, Belgium, 2009.
- Bird R.B., Stewart W.E., Lightfoot E.N., *Transport Phenomena*. Wiley, New York, 1960.
- Carlson J.D., Spencer Jr. B.F., *Magneto-Rheological Fluid Dampers for Semi-Active Seismic Control*. 3<sup>rd</sup> Int. Conf. on Motion and Vibration Control, Chiba, Japan, Vol. 3, 35–40, 1996.
- Chen D., Xu J., Pan J., Guo X., Sun W., *Research and Prospect of Automobile Magneto-Rheological Fluid Dual Clutch Transmission*. 2<sup>nd</sup> Int. Conf. on Electronic & Mechanical Engineering and Information Technology, EMEIT-2012, Atlantis Press, Paris, France, 98–102, 2012.
- Chilton R.A., Stainsby R., *Pressure Loss Equations for Laminar and Turbulent Non-Newtonian Pipe Flow*. Journal of Hydraulic Engineering, **124**, 522, 1998.

- Craig B., *One Fluid, Multiple Viscosities - Numerous Applications, Active Fluids are Changing Damping Technology Forever*. AMPTIAC Quarterly, **7**, 15–19, 2003.
- David C., Behzad T., Edmond R., *Dynamic Magnetorheological Damper for Orthotic Tremor Suppression*. Biomedical Engineering and Technology Mechatronics/MEMS/NEMS/Robotics/Automation Department of Mechanical Engineering Bobby B. Lyle School of Engineering Southern Methodist University, Dallas, <http://www.huichawaii.org/assets/riche,-edmond-1.pdf>.
- Goncalves F.D., *Characterizing the Behavior of Magnetorheological Fluids at High Velocities and High Shear Rates*. Ph. D. Thesis, State University and Polytechnic Institute of Virginia, Blacksburg, Virginia, USA, 2005.
- Herschel W.H., Bulkley R., *Konsistenzmessungen von Gummi-Benzollösungen*. Kolloid Zeitschrift, **39**, 291–300, 1926.
- Huang J., Zhang J.Q., Yang Y., Wei Y.Q., *Analysis and Design of a Cylindrical Magneto-Rheological Fluid Brake*. Journal of Materials Processing Technology, **129**, 559–562, 2002.
- Janusz G., Sapinski B., *Nondimensional Characterization of Flow-Mode Magneto-Rheological/Electrorheological Fluid Dampers*. Journal of Intelligent Material Systems and Structures, **23**, 1545–1562, 2012.
- Kciuk M., Turczyn R., *Properties and Application of Magneto Rheological Fluids*. Journal of Achievement in Material and Manufacturing Engineering, **18**, 127–130, 2006.
- Klein W., Mezyk A., Otorowski M., *The Application Overhaul of Magnetorheological Fluids in Mechanical Engineering*. XIII International Scientific Conference TEMAG, Gliwice-Ustron, 95–105, 2005.
- Klingenberg D.J., *Magnetorheology: Applications and Challenges*. AIChE Journal, **47**, 246–249, 2001.
- Muhammad A., Yao X., Deng Z., *Review of Magneto Rheological (MR) Fluid and its Application in Vibration Control*. Journal of Marine Science and Application, **5**, September 2006, 17–29, 2006.
- Pranoto T., Nagaya K., *Development on 2DOF-Type and Rotary-Type Shock Absorber Damper Using MRF and Their Efficiencies*. Journal of Materials Processing Technology, **161**, 146–150, 2005.
- Siginer D.A., De Kee D., Chhabra R.P., *Advances in the Flow and Rheology of Non-Newtonian Fluids*, **8**, Elsevier, 1999.
- Susan-Resiga D., *A Rheological Model for Magneto-Rheological Fluids – 3<sup>rd</sup> German-Romanian Workshop on Turbomachinery Hydrodynamics*, May 10-12, 2007, 141–158, 2007.
- Susan-Resiga D., Bica D., Vekas L., *Flow Behaviour of Extremely Bidisperse Magnetizable Fluids*. Journal of Magnetism and Magnetic Materials, **322**, 3166–3172, 2010.
- Zhou L., Wen W., Sheng P., *Ground States of Magnetorheological Fluids*. Physical Review Letters, **81**, 1509–1512, 1998.

---

INFLUENȚA UNOR FACTORI EXTERNI ASUPRA  
CURGERII FLUIDELOR MAGNETO-REOLOGICE (MRF)  
PRIN CONDUCTE CIRCULARE

(Rezumat)

În prezent, o serie tot mai largă de aplicații din industrie și nu numai, se dezvoltă pe baza materialelor inteligente. Aceste materiale, între care se încadrează și fluidele magneto-reologice, au proprietatea de a-și modifica forma, mărimea sau proprietățile la modificarea temperaturii, a umidității sau prin aplicarea unui câmp magnetic exterior.

Aplicațiile fluidelor magneto-reologice se întâlnesc în domenii cu impact major asupra mediului precum industria automobilelor, construcții civile și speciale (protecție împotriva efectelor seismelor, absorbția șocurilor și vibrațiilor), industria aparatelor medicale (proteze și aparatură pentru reabilitare musculară), industria militară etc.

Utilizarea fluidelor magneto-reologice în diverse aplicații presupune cunoașterea comportării acestora din punct de vedere al fenomenelor complexe de curgere.

Lucrarea propune un model matematic pentru curgerea cu gradient de presiune a unui fluid magneto-reologic, considerat ca un fluid nenenewtonian de tip Bingham, printr-o conductă circulară, utilizând ecuațiile Navier-Stokes în coordonate cilindrice și analiza experimentală a acestui fenomen.

Modelul matematic propus ia în considerare caracterul axial-simetric al mișcării și permite determinarea comportării unui fluid magneto-reologic la curgerea sub presiune prin conducte circulare.

Standul conceput permite determinarea comportării fluidului magneto-reologic atât în absența câmpului magnetic exterior aplicat, cât și în prezența acestuia. Datele experimentale obținute validează modelul matematic propus.

Încercările efectuate în prezența câmpului magnetic exterior aplicat arată posibilitatea controlului parametrilor de curgere prin conducta circulară.